

FEMALE END VIEW

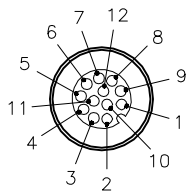

- 1 = WHITE
- 2 = BROWN
- 3 = GREEN
- 4 = YELLOW
- 5 = GREY
- 6 = PINK
- 7 = BLUE
- 8 = RED
- 9 = ORANGE
- 10 = TAN
- 11 = BLACK
- 12 = VIOLET



SPECIFICATIONS

CONTACT CARRIER MATERIAL	TPU
MOLDED HEAD MATERIAL/COLOR	TPU/YELLOW
CONTACT MATERIAL/PLATING	BRASS/GOLD
COUPLING NUT MATERIAL/PLATING	BRASS/NICKEL
RATED CURRENT [A]	2.0 A
RATED VOLTAGE [V]	30 V
OUTER CABLE JACKET MATERIAL/COLOR	TPE/BLACK
CONDUCTOR INSULATION MATERIAL	POLYESTER ELASTOMER
NUMBER OF CONDUCTORS [AWG]	12x24 AWG
TEMPERATURE RANGE	-40°C to +105°C (-40°F to +221°F)
PROTECTION CLASS	NEMA 1,3,4,6P AND IEC IP68, IP69K

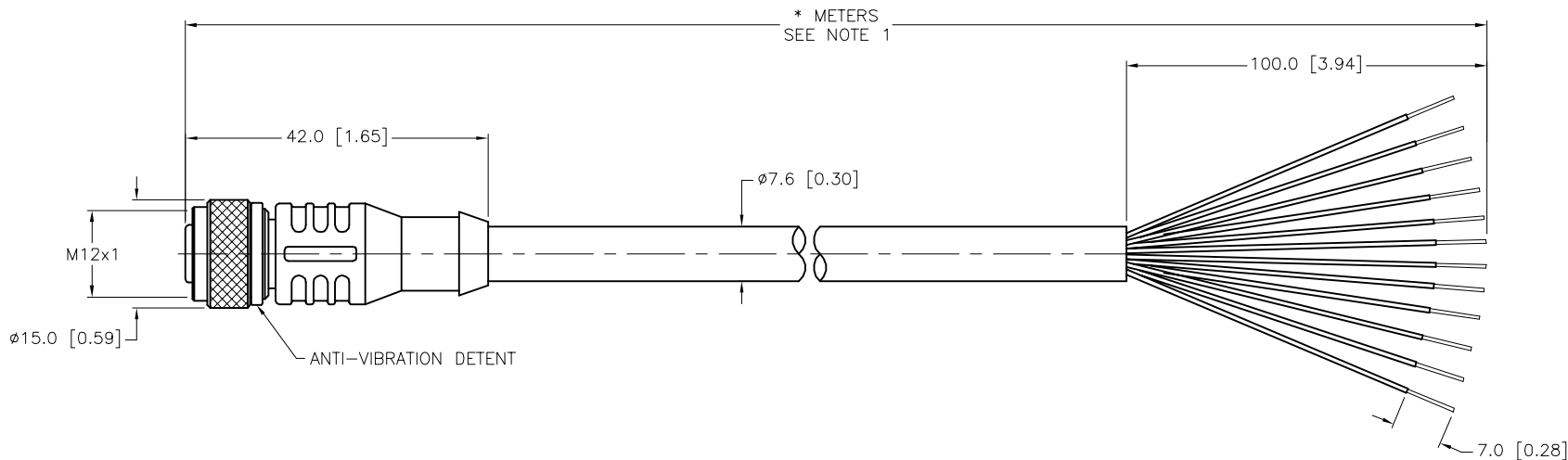

CABLE LENGTH	TOLERANCE*
ALL LENGTHS	+ 4% (OR 50mm) OF LENGTH - 0% (OR 0mm) OF LENGTH WHICHEVER IS GREATER
STRIP LENGTH	TOLERANCE*
0-7mm	±0.5mm
8-29mm	±1.0mm
30-49mm	±2.0mm
50-69mm	±3.0mm
70-100mm	±4.0mm
OVER 100mm	±5.0mm
* UNLESS OTHERWISE SPECIFIED	

NOTES:

1. "*" DESIGNATES CABLE LENGTH IN METERS. CONTACT TURCK TO ORDER SPECIFIC LENGTHS.
2. "/S101" DESIGNATES FLEXLIFE-20 AND C-TRACK CABLE.

SOURCE DRAWING - FOR REFERENCE ONLY

RELATED DOCUMENTS 1. 2. 3. 4.	3RD ANGLE PROJECTION 	THIS DRAWING IS CONFIDENTIAL AND THE PROPERTY OF TURCK INC. USE OF THIS DOCUMENT WITHOUT WRITTEN PERMISSION IS PROHIBITED.		3000 CAMPUS DRIVE MINNEAPOLIS, MN 55441 1-800-544-7769 (763) 553-7300 (763) 553-0708 fax www.turck.us	
		DRFT	RDS		
MATERIAL	ALL DIMENSIONS DISPLAYED ON THIS DRAWING ARE FOR REFERENCE ONLY	APVD	SCALE	DESCRIPTION RKC 12T-*/S101	
SEE SPECIFICATIONS		UNIT OF MEASUREMENT MILLIMETER [INCH]		IDENTIFICATION NO.	
FINISH	CONTACT TURCK FOR MORE INFORMATION	DO NOT SCALE THIS DRAWING		REV J	
SEE SPECIFICATIONS		FILE: 777002428		SHEET 1 OF 1	

J	UPDATE VOLTAGE RATING	CBM	02/21/23	78300
REV	DESCRIPTION	BY	DATE	ECO NO.